

DT Membrane Module

Product model: HP12.0-DT-RO4-9.405-SS316L

Product parameters:

Max. Operating Pressure	Effective Membrane Area	Temperature Max.	pH range	Wet Weight	Rejection	Flux
120bar	9.405 m ²	45°C	3-11 (Operating) 2-12 (CIP)	100kg	98% ⁽¹⁾	200L/h ⁽¹⁾

⁽¹⁾ **Test conditions:** Inlet pressure 90±2bar, Temperature 25 ± 3 °C, Feed flow 800±50L/h, Conductivity 65000 ± 1000us/cm (NaCl solution).

Dimensions:

Component dimension drawing

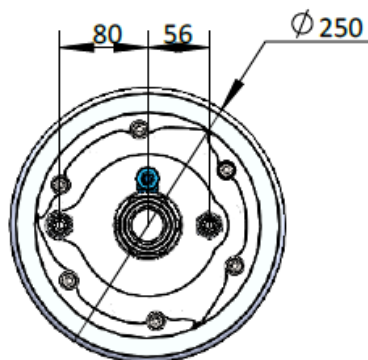
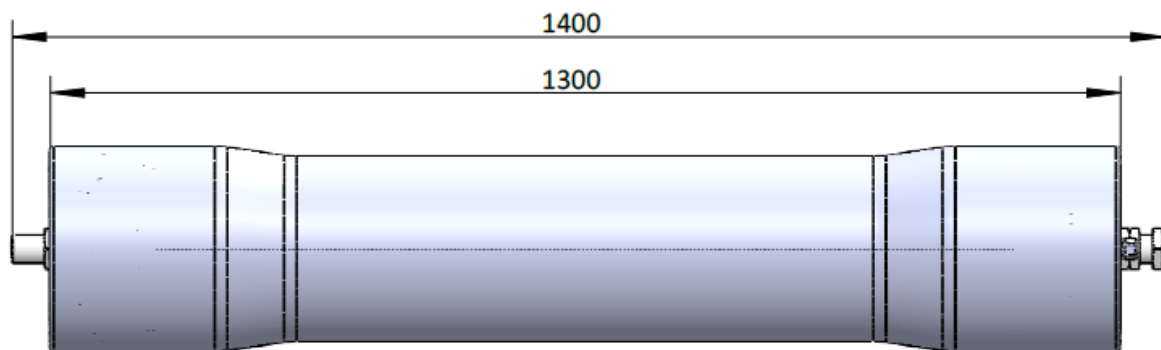

Bottom Flange

Bottom Flange

High pressure nozzle: Φ12mm High pressure connecting pipe
Permeate connection: Φ9mm hose

Note: the feed can only be connected to the inlet connection.
Do not connect to outlet (concentrate) connection